



®Eberspächer

# Ersatzteilliste B 3 L/D 3 L

Parts list  
Reservdelar  
Pieces de rechange

J. Eberspächer  
Eberspächerstr. 24  
D-73730 Esslingen  
Telefon (zentral)  
(07 11) 9 39-00  
Telefax  
(07 11) 9 39-05 00

Gültig für die Geräte-Ausführungen  
For heater designs  
Gäller för följande värm retyper  
Valables pour les modèles d'appareille

## B 3 L

20 1643 00 00 00 - 12 Volt

## D 3 L

25 1482 00 00 00 - 12 V  
25 1552 00 00 00 - 12 V  
25 1640 00 00 00 - 12 V  
25 1738 00 00 00 - 12 V

25 1483 00 00 00 - 24 V  
25 1573 00 00 00 - 24 V  
25 1641 00 00 00 - 24 V  
25 1642 00 00 00 - 24 V  
25 1739 00 00 00 - 24 V

Bestellnummer und  
Verkaufseinheit (VE)

Ersatzteile können nur in Verkaufseinheiten (VE) geliefert werden. Bei Angabe der benötigten Stückzahl beachten Sie bitte, daß die Bestell-Nr. bereits die in Spalte 3 angegebene Stückzahl umfaßt.

Order No. and  
package counts (VE)

Spare parts can only be supplied in specific package counts (VE). When stating the quantity required, please note that the Order No. already covers the quantity shown in col. 3.

Beställningsnummer och  
beställningsenhet (VE)

Reservdelar kan endast levereras i beställningsenheter (VE). Vid uppgift av erforderligt antal, v g observera att beställningsnumret avser det i spalt 3 angivna antalet i styck.

N° de commande et  
quantité de commande (VE)

Les pièces de rechange ne peuvent être fournies qu'en quantités de commande spécifiques (VE). En indiquant la quantité voulue, veuillez noter que le N° de commande couvre déjà la quantité indiquée dans la col. 3.

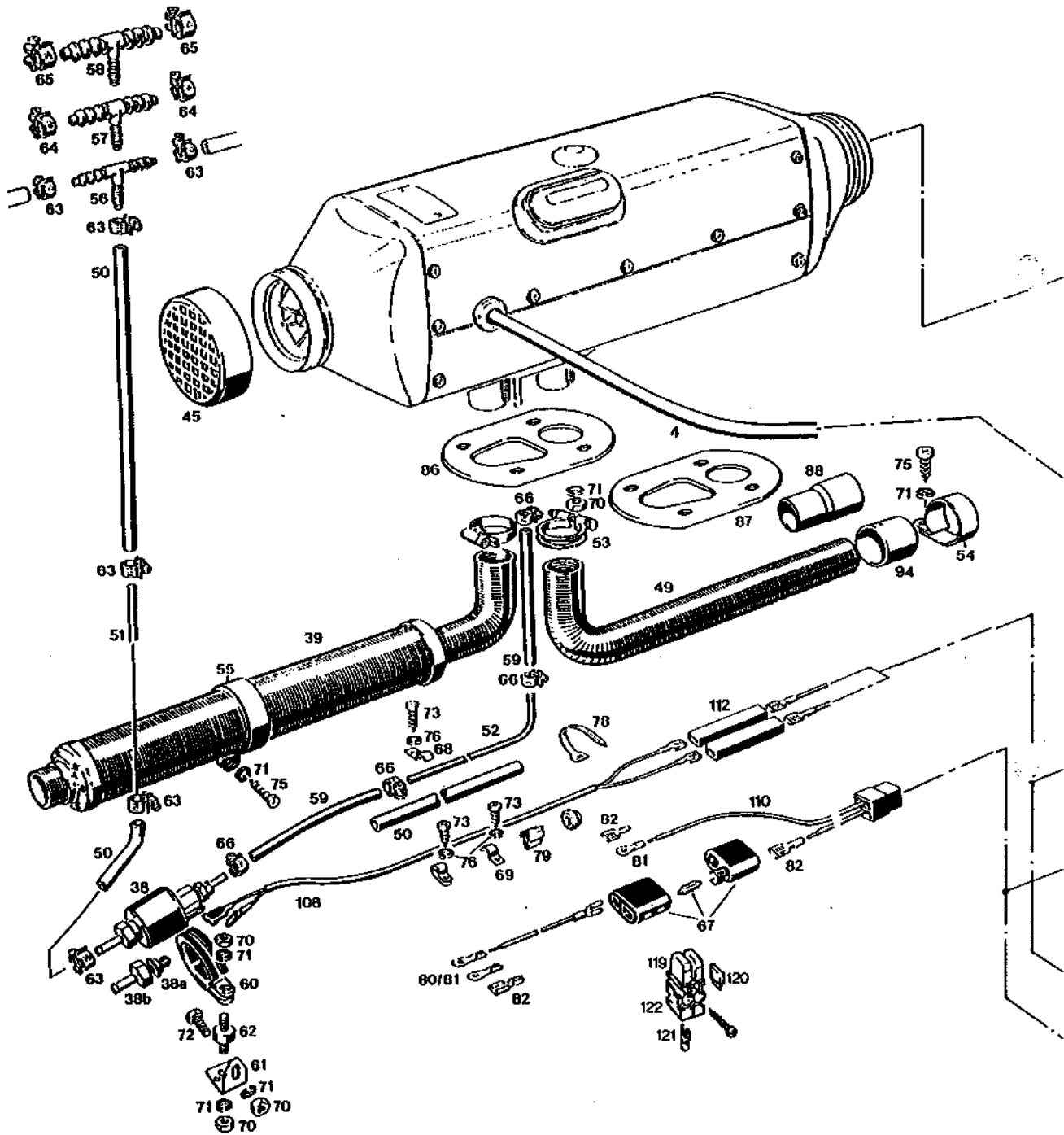

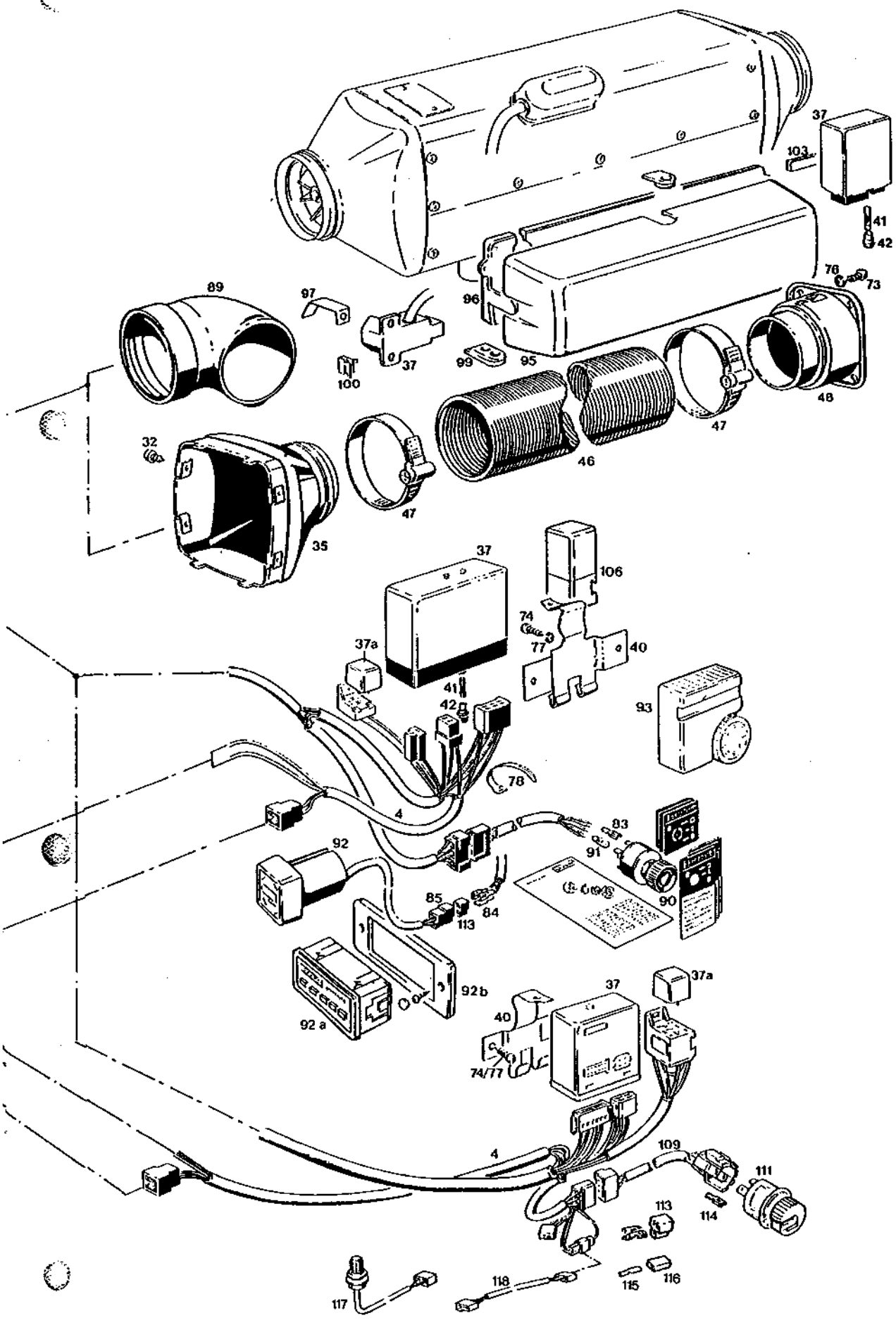

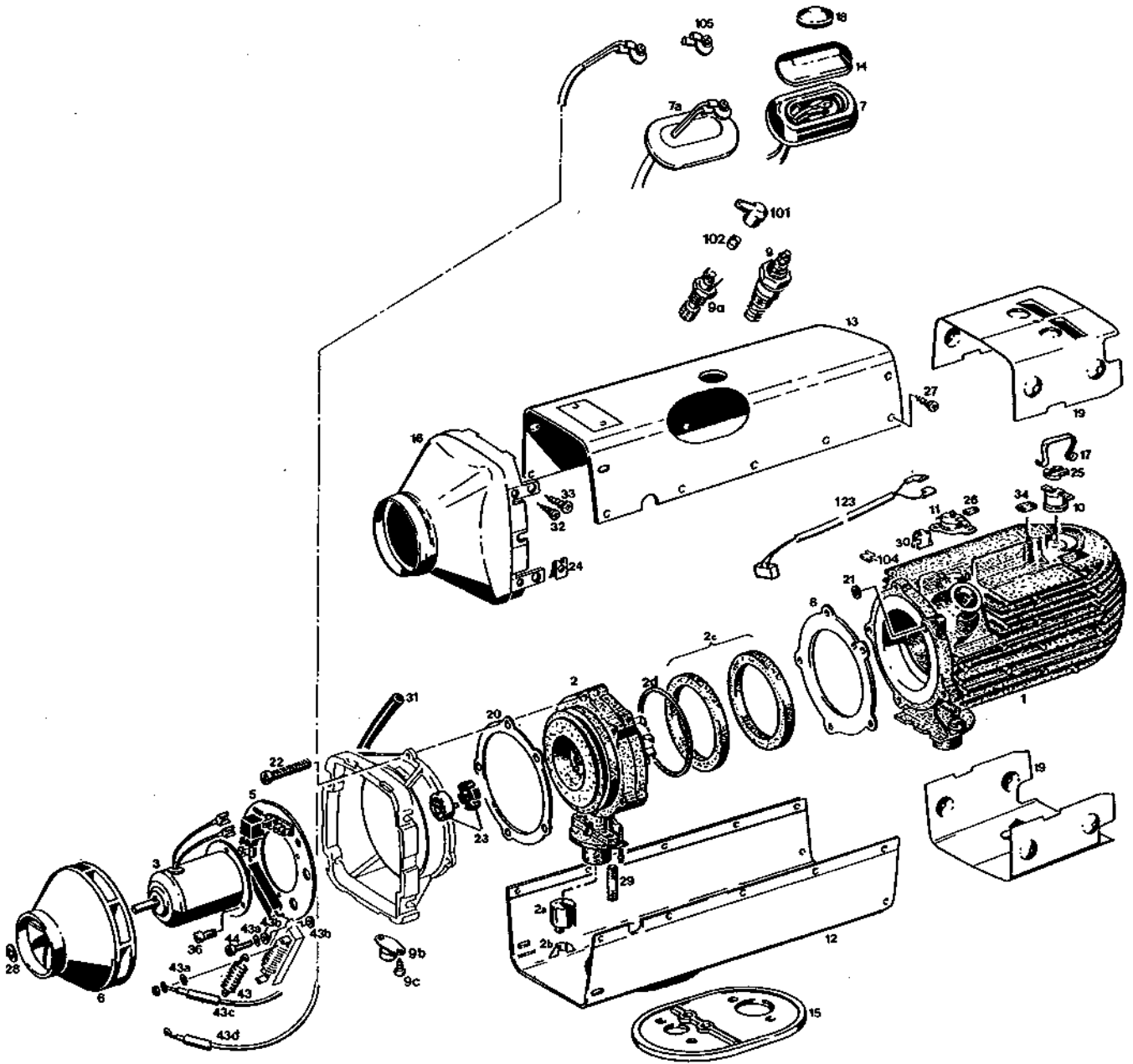

H = handelsübliche – Teile müssen im Fachhandel selbst beschafft werden.  
 H = commercially available – parts to be procured from specialized trade.  
 H = Tillgänglig i handeln – delarna måste man själv anskaffa i fackhandeln.  
 H = dans le commerce – se procurer pièces dans le commerce spécialisé.

n. B. = nach Bedarf  
 as required  
 efter behov  
 suivant besoin



Bild-Nr. Fig. No. Bild nr. Fig. No.	Stückzahl pro Gerät Req. per heater Styck per aggregat Quantité par appareil	Stückzahl pro VE Pkg. count Styck par beställning- senhet Quantité minimale	Benennung Designation Benämning Désignation	Bestell-Nr. Order No. Beställningsnr. No. Référence	25 1573										
					25 1482	25 1483	25 1552	20 1643	25 1640	25 1641	25 1642	25 1738	25 1739		
1	1	1	Wärmetauscher mit Brennkammer Heat exchanger Värmeväxlare Echangeur de chaleur	25 1482 06 00 00 20 1643 06 00 00	●	●	●	●	●	●	●	●	●	●	
2	1	1	Verbrennungsluftgebläse, eingestellt Combustion air blower Förbränningsluftfläkt Turbine d'air de combustion	25 1482 99 15 00 25 1552 99 15 00 20 1643 99 15 00	●	●	●	●	●	●	●	●	●	●	
2a	1	1	Blendenstopfen vollst. Combustion air volume regulating plug, complete Reglage för förbränningsluftmängd, complett Bouchon diaphragme, complet	25 1482 99 02 00 25 1552 99 02 00	●	●	●	●	●	●	●	●	●	●	
2b	1	10	Klammer Clamp Klämma Pince	25 1482 01 00 10	●	●	●	●	●	●	●	●	●	●	
2c	2 1	2 2	Dochtring Feltring Vekring Bague-feutre	25 1482 15 00 03	●	●	●	●	●	●	●	●	●	●	
2d	1	1	Runddichtring Sealing Tätningring Rondelle joint	320 75 188	●	●	●	●	●	●	●	●	●	●	
3	1	1	Elektromotor 12 V Electric motor Elmotor Moteur électrique	25 1482 01 01 00 25 1552 01 01 00	●	●	●	●	●	●	●	●	●	●	
-	1	1	Elektromotor 24 V Electric motor Elmotor Moteur électrique	25 1483 01 01 00 25 1553 01 01 00	●	●	●	●	●	●	●	●	●	●	
4	1	1	Kabelbaum Cable tree Kabelförgrening Faisceau de câble	*25 1482 01 06 00 *25 1552 01 06 00 *20 1643 01 06 00	●	●	●	●	●	●	●	●	●	●	
-	1	1	Kabelbaum Cable tree Kabelförgrening Faisceau de câble	25 1483 → *25 1483 01 06 00 25 1573 → *25 1573 01 06 00 *25 1641 01 06 00 *25 1642 01 06 00 *25 1738 01 11 00	●	●	●	●	●	●	●	●	●	●	●
5	1	1	Leiterplatte 12 V, vollst. Printed circuit board Ledarplatta Plaque à circuits imprimés	25 1482 01 05 00 20 1643 01 05 00 25 1640 01 05 00 25 1738 01 10 00	●	●	●	●	●	●	●	●	●	●	
-	1	1	Leiterplatte 24 V, vollst. Printed circuit board Ledarplatta Plaque à circuits imprimés	25 1483 01 04 00 25 1641 01 04 00 25 1739 01 10 00	●	●	●	●	●	●	●	●	●	●	

\*Nicht ab Lager lieferbar;  
Fertigung auf Bestellung.

\*Normally not available;  
manufacture against order.

5

\*Kan i regel inte levereras genast;  
tilverkning vid beställning.

\*Ne pas disponible normalement;  
sera construit sur demande.

Bild-Nr. Fig. No. Bild nr. Fig. No.	Stückzahl pro Gerät Req. per heater Styck per aggregat Quantité par appareil	Stückzahl pro VE Pkg. count Styck par beställning- senhet Quantité minimale	Benennung Designation Benämning Désignation	Bestell-Nr. Order No. Beställningsnr. No. Référence	25 1482 / 25 1573								
					25 1482	25 1483	25 1552	20 1643	25 1640	25 1641	25 1642	25 1738	25 1739
6	1	1	Heizlufttrad, vollst. Fan wheel Ventilatorhjul Roue de turbine	25 1482 20 02 00	●	●	●	●	●	●	●	●	●
7	1	1	Tülle mit Kabel Sleeve Genomföring Passe-câble	25 1482 01 04 00 25 1483 01 02 00 20 1643 01 04 00	●	●		●					
7a	1	1	Tülle mit Kabeln Sleeve Genomföring Passe-câble	25 1482 01 07 00 25 1483 01 09 00 25 1738 01 07 00 25 1739 01 07 00	●			●		●	●	●	●
8	1	5	Dichtung Sealing Packning Joint	25 1482 01 00 04	●	●	●	●	●	●	●	●	●
9	1	1	Glühkerze Glow plug Glödstift Bougie de réchauffage et d'allumage	25 1384 01 00 02 (25 1384 01 00 10)	●	●	●		●	●	●	●	●
9a	1	1	Glühzündkerze Glow spark plug Glödständstift Bougie de réchauffage et d'allumage	20 1643 01 00 11				●					
9b	1	1	Glühwendelschalter Heating coil switch Glödspiralbrytare Interrupteur du filament boudine	20 1643 01 00 03				●					
9c	2	-	Blechschaube B 3,5x6,5 Z 1 DIN 7981 ZN12 Sheer-metal screw Plåtskruv Vis Parker	H				●					
10	1	1	Thermoschalter Temperature switch Termoströmsställare Thermo-rupteur	25 1482 01 00 09 25 1729 37 00 00	●	●	●	●	●	●	●	●	●
10a	1	1										●	●
11	1	1	Überhitzungsschalter Safety thermal cutout switch Overhötningsskydd Interrupteur de surchauffe	25 1382 40 00 02 25 1738 40 00 00	●	●	●	●	●	●	●	●	●
12	1	1	Untere Mantelhälfte Lower half of casing Undre mantelhalva Partie inférieure d'enveloppe	25 1482 02 01 01	●	●	●	●	●	●	●	●	●
13	1	1	Obere Mantelhälfte Upper half of casing Ovre mantelhalva Partie supérieure d'enveloppe	25 1482 02 06 01	●	●	●	●	●	●	●	●	●



Bild-Nr. Fig. No. Bild nr. Fig. No.	Stückzahl pro Gerät Req. per heater Styck per aggregat Quantité par appareil	Stückzahl pro VE Pkg. count Styck par beställning- senhet Quantité minimale	Benennung Designation Benämning Désignation	Bestell-Nr. Order No. Beställningsnr. No. Référence	25 1482 / 25 1573								
					25 1482	25 1483	25 1552	20 1643	25 1640	25 1641	25 1642	25 1738	25 1739
14	1	1	Kappe Cap Kåpa Gaine de protection	25 1482 01 00 05 20 1643 01 00 02	●	●	●	●	●	●	●	●	●
15	1	1	Flanschdichtung Sealing Packing Joint	25 1482 01 00 07 25 1738 01 00 02	●	●	●	●	●	●	●	●	●
16	1	1	Einströmhitze Hood Hur Hotte	25 1482 02 01 02	●	●	●	●	●	●	●	●	●
17	1	2	Haltefeder Carrier Säkringshållare Porte fusible	25 1380 01 00 04	●	●	●	●	●	●	●	●	●
18	1	1	Tülle Sleeve Genomföring Passe-câble	25 1382 01 00 02	●	●	●	●	●	●	●	●	●
19	2	1	Wärmeschutzblech Upper heat protection plate Värmskyddsplåt Tole d'isolation carlorifuge	25 1482 01 00 08	●	●	●	●	●	●	●	●	●
20	1	1	Dichtung Sealing Packing Joint	25 1482 01 00 11	●	●	●	●	●	●	●	●	●
21	1	5	Dichtring Sealing Tätning Rondelle joint	25 1482 01 00 12	●	●	●	●	●	●	●	●	●
22	5	20	Linsenschraube M 5 x 40 Fillister head bolt Skruv Vis à tête bombée	103 10 326	●	●	●	●	●	●	●	●	●
23	1	1	Kupplung, vollst. Coupling Koppling Accouplement	25 1426 99 55 00	●	●	●	●	●	●	●	●	●
24	8	100	Blechmutter, C-Clip Sheet-metal nut låtmutter Ecrou	119 32 020	●	●	●	●	●	●	●	●	●
25	1	5	Zwischenstück Holder Hållare Support	206 00 160	●	●	●	●	●	●	●	●	●

Bild-Nr. Fig. No. Bild nr. Fig. No.	Stückzahl pro Gerät Req. per heater Styck per aggregat Quantité par appareil	Stückzahl pro VE Pkg. count Styck par beställning- senhet Quantité minimale	Benennung Designation Benämning Désignation	Bestell-Nr. Order No. Beställningsnr. No. Référence	25 1482 / 25 1573								
					25 1482	25 1483	25 1552	20 1643	25 1640	25 1641	25 1642	25 1738	25 1739
26	2	10	Sicherung, mechanisch Clip Klämma Porte	171 42 080	•	•	•	•	•	•	•	•	•
27	10 5	-	Blechschaube B 3,5 x 9,5 Z1 DIN 7981 Zn 12 Sheer-metal screw Plåtskruv Vis Parker	H	•	•	•	•	•	•	•	•	•
28	1	20	Sperrscheibe, lösbar Lock washer Spärrbricka Anneau de retenue	171 19 190	•	•	•	•	•	•	•	•	•
29	4	1	Stiftschraube M 6 x 20 Grub screw Pinnskruv Goujon fileté	106 10 022	•	•	•	•	•	•	•	•	•
30	1	1	Kabelbefestiger Cable Kabel Câble	156 22 010	•	•	•	•	•	•	•	•	•
31	1	1	Schlauch Hose Slang Conduite	360 31 006	•	•	•	•	•	•	•	•	•
32	8	-	Blechschaube B 3,5 x 13 Z1 DIN 7981 Zn 12 Sheet-metal screw Plåtskruv Vis Parker	H	•	•	•	•	•	•	•	•	•
33	4	-	Blechschaube B 3,5 x 13 DIN 7981 Zn 12 Sheet-metal screw Plåtskruv Vis Parker	H	•	•	•	•	•	•	•	•	•
34	2	10	Sicherung mechanisch Clip Klämma Porte	171 42 082	•	•	•	•	•	•	•	•	•
35	1	1	Ausströmhitze, gerade, vollst. Hood Hur Hotte	25 1482 02 08 00	•	•	•	•	•	•	•	•	•
36	n.B.	-	Linsenschraube M 4 x 12, Z4 DIN 7985 -4,8 Zn 8 Fillister head bolt Skruv Vis à tête bombée	H	•	•	•	•	•	•	•	•	•
37	1	1	Steuergerät 12 V Control unit Styrenhet Coffret de commande automatique	20 1607 50 00 00 25 1484 50 00 00 25 1688 50 00 05	•	•	•	•	•	•	•	•	•
-	1	1	Steuergerät 24 V Control unit Styrenhet Coffret de commande automatique	25 1483 50 00 00 25 1689 50 00 06	•	•	•	•	•	•	•	•	•





Bild-Nr. Fig. No. Bild nr. Fig. No.	Stückzahl pro Gerät Req. per heater Styck per aggregat Quantité par appareil	Stückzahl pro VE Pkg. count Styck par beställning- senhet Quantité minimale	Benennung Designation Benämning Désignation	Bestell-Nr. Order No. Beställningsnr. No. Référence	25 1482 / 25 1573												
					25 1482	25 1483	25 1552	20 1643	25 1640	25 1641	25 1642	25 1738	25 1739				
37a	1	1	Relais Relay Relä Relais	12 V 203 00 065 24 V 203 00 066 12 V 203 00 082 24 V 203 00 084		•				•							
37b	1	1	Zündfunktgeber Ignition coil Tändningsgnistgivare Excitateur d'allumage	20 1643 01 01 00													
38	1	1	Brennstoffdosierpumpe 12 V Fuel metering pump Bränsledoseringspump Pompe de dosage de carburant	25 1482 47 00 00 20 1643 47 00 00	•		•			•							
-	1	1	Brennstoffdosierpumpe 24 V Fuel metering pump Bränsledoseringspump Pompe de dosage de carburant	25 1483 47 00 00		•					•	•					•
38a	1	20	Topfsieb Pot-shaped strainer Kärilsil Filtre en forme de pot	20 1312 00 00 06	•	•	•	•	•	•	•	•	•	•	•	•	•
38b	1	1	Schlauchstutzen Hose connection Slangstuts Tubulare	20 1621 45 00 02	•	•	•	•	•	•	•	•	•	•	•	•	•
39	1	1	Ansaugschalldämpfer Intake silencer Insugningsljuddämpare Silencieux, côte aspiration	20 1451 01 01 00	•	•		•	•	•	•	•	•	•	•	•	•
40	1	1	Halter Holder Hållare Support	25 1597 80 00 01 25 1688 65 00 01	•	•	•		•	•	•				•	•	
41	1	1	Ersatzsicherung 2 Stck. (TT 4 - 460 26 016 blauer Ring) Replacement fuse Reservdels-säkring Fusible de rechange	25 1531 05 02 00	•				•	•							
-	1		Sicherungseinsatz (T 8 - weißer Ring) Replacement fuse Reservdels-säkring Fusible de rechange	204 00 090				•									
-	1	1	Ersatzsicherung 2 Stck. (TT 2 - 460 26 000 gelber Ring) Replacement fuse Reservdels-säkring Fusible de rechange	25 1532 05 02 00		•					•	•					

Bild-Nr. Fig. No. Bild nr. Fig. No.	Stückzahl pro Gerät Req. per heater Styck per aggregat Quantité par appareil	Stückzahl pro VE Pkg. count Styck par beställning- senhet Quantité minimale	Benennung Designation Benämning Désignation	Bestell-Nr. Order No. Beställningsnr. No. Référence	25 1482 / 25 1573												
					25 1482	25 1483	25 1552	20 1643	25 1640	25 1641	25 1642	25 1738	25 1739				
42	1	1	Kappe Cap Kápa Gaine de protection	204 00 102	●	●	●	●	●	●	●						
43	1	1	Widerstandswendel Series resistor Förkopplingsmotstand Résistance en série	203 00 138		●				●	●						●
43a	2	-	Scheibe 4,3 DIN 125 - St Zn 12 Disc Platta Rondelle	H		●				●	●						●
43b	4	10	Scheibe Disc Platta Rondelle	25 1483 01 00 02		●				●	●						●
43c	1	1	Leitung mit Sicherung Cable with fuse Kabelförgrening med säkring Câble avec fusible	25 1483 99 04 00		●											
43d	1	1	Leitung, vollst. Cable Kabelförgrening Câble	25 1483 99 05 00		●				●	●						●
44	2	-	Linsenschraube M 4 x 20 DIN 7985 - 4,8 Zn 8 Fillister head bold Skruv Vis à tête bombée	H		●				●	●						●
45	1	1	Schutzgitter Protective grille Skyddsgaller Grille de protection	25 1552 05 01 00	●	●	●	●	●	●	●	●	●	●	●	●	●
46	n.B.	lfdm	Flexibles Rohr ø 75 mm Flexible pipe Böjligt rör Tuyau flexible	10 2114 34 00 00	●	●		●	●	●	●	●	●	●	●	●	●
-	n.B.	lfdm	Flexibles Rohr ø 75 mm F-F-K Flexible pipe Böjligt rör Tuyau flexible	360 00 130			●										
47	2	1	Schlauchschelle ø 70-90 mm Hose clip Slangklämna Collier de serrage	10 2064 07 00 90	●	●		●	●	●	●	●	●	●	●	●	●
48	1	1	Ausströmer, drehbar ø 75/100 mm Heating shaft rotatable Utlopp rörligt Cône d'évacuation	22 1050 89 21 00	●	●		●	●	●	●	●	●	●	●	●	●
49	n.B.	lfdm	Flexibles Wendelrohr ø 24 I.W. Helicat tube Böjligt spiräl rör Tuyau hélicoidal, flexible	360 61 299	●	●	●	●	●	●	●	●	●	●	●	●	●



Bild-Nr. Fig. No. Bild nr. Fig. No.	Stückzahl pro Gerät Req. per heater Styck per aggregat Quantité par appareil	Stückzahl pro VE Pkg. count Styck par beställning- senhet Quantité minimale	Benennung Designation Benämning Désignation	Bestell-Nr. Order No. Beställningsnr. No. Référence	25 1482 / 25 1573								
					25 1482	25 1483	25 1552	20 1643	25 1640	25 1641	25 1642	25 1738	25 1739
50	n.B.	lfdm	Schlauch 5 x 3 Hose Slang Tuyau	360 75 350	●	●		●	●	●	●	●	●
51	n.B.	lfdm	Kunststoffrohr 6 x 2 Plastic pipe Plaströr Tuyau en plastique	090 31 125	●	●		●	●	●	●	●	●
52	n.B.	lfdm	Kunststoffrohr 4 x 1,25 Plastic pipe Plaströr Tuyau en plastique	090 31 118	●	●		●	●	●	●	●	●
53	1	1	Rohrschelle ø 27/30 Pipe clip Rörklämna Collier de serrage	152 10 060	●	●		●	●	●	●	●	●
54	1	1	Rohrschelle ø 28/15 Pipe clip Rörklämna Collier de serrage	152 10 051	●	●		●	●	●	●	●	●
55	1	1	Rohrschelle ø 50/15 Pipe clip Rörklämna Collier de serrage	152 10 047	●	●		●	●	●	●	●	●
-	2		Rohrschelle ø 26/28 Pipe clip Rörklämna Collier de serrage	152 61 102			●						
-	n.B.	lfdm	Flexibles Wendelrohr ø 25 mm l.W. Helicate tube Böjligt spirallrör Tuyau hélicoïdal	360 61 265			●						
56	1	1	T-Stück 6 - 6 - 6 T-piece T-stycke Raccord en T	262 31 150	●	●		●	●	●	●	●	●
57	1	1	T-Stück 8 - 6 - 8 T-piece T-stycke Raccord en T	262 31 151	●	●		●	●	●	●	●	●
58	1	1	T-Stück 12 - 6 - 12 T-piece T-stycke Raccord en T	262 31 153	●	●		●	●	●	●	●	●
59	n.B.	lfdm	Schlauch 3,5 x 3 Hose Slang Tuyau	360 75 300	●	●		●	●	●	●	●	●

Bild-Nr. Fig. No. Bild nr. Fig. No.	Stückzahl pro Gerät Req. per heater Styck per aggregat Quantité par appareil	Stückzahl pro VE Pkg. count Styck par beställning- senhet Quantité minimale	Benennung Designation Benämning Désignation	Bestell-Nr. Order No. Beställningsnr. No. Référence	25 1482 / 25 1483 / 25 1552 / 20 1643 / 25 1640 / 25 1641 / 25 1642 / 25 1738 / 25 1739								
					25 1482	25 1483	25 1552	20 1643	25 1640	25 1641	25 1642	25 1738	25 1739
60	1	1	Rohrschelle $\phi$ 34/15 Pipe clip Rörklämma Collier de serrage	152 00 144	●	●	●	●	●	●	●	●	●
61	1	1	Winkelstück Angle element Vinkelstycke Equerre	20 1348 03 00 02	●	●	●	●	●	●	●	●	●
62	1	1	Metallgummipuffer Metala-rubber-buffer Metallgummifot Amortisseur métal-caoutchouc	20 1185 00 00 01	●	●	●	●	●	●	●	●	●
63	6	1	Schlauchschelle $\phi$ 11 mm Hose clip Slangklämma Collier de serrage	10 2063 01 10 98	●	●	●	●	●	●	●	●	●
64	2	1	Schlauchschelle $\phi$ 12 mm Hose clip Slangklämma Collier de serrage	10 2063 01 20 98	●	●	●	●	●	●	●	●	●
65	2	1	Schlauchschelle $\phi$ 14 mm Hose clip Slangklämma Collier de serrage	10 2063 01 40 98	●	●	●	●	●	●	●	●	●
66	4	1	Schlauchschelle $\phi$ 9 mm Hose clip Slangklämma Collier de serrage	10 2063 00 90 98	●	●	●	●	●	●	●	●	●
67	1	1	Sicherungshalter mit 16 A-Sicherung Fuse carrier (with 16 A fuse) Säkringshållare (med 16 Amp.-Säkring) Porte fusible (avec fusible 16 A)	204 00 099	●	●	●	●	●	●	●	●	●
68	1	100	Befestigungsschelle 1x4 Mounting clip Fastsättningsklämma Collier de fixation	152 10 003	●	●	●	●	●	●	●	●	●
69	2	100	Befestigungsschelle 1x6 Mounting clip Fastsättningsklämma Collier de fixation	152 10 005	●	●	●	●	●	●	●	●	●
70	7	-	Sechskantmutter M 6 DIN 934 - 5 Zn 8 Hexagon nut Sextantskruv Vis à six pans	H	●	●	●	●	●	●	●	●	●
71	10	-	Federscheibe B 6 DIN 137 Zn 12 Spring Lockwasher Fjäderbricka Rondelle élastique	H	●	●	●	●	●	●	●	●	●



Bild-Nr. Fig. No. Bild nr. Fig. No.	Stückzahl pro Gerät Req. per heater Styck per aggregat Quantité par appareil	Stückzahl pro VE Pkg. count Styck par beställning- senhet Quantité minimale	Benennung Designation Benämning Désignation	Bestell-Nr. Order No. Beställningsnr. No. Référence									
					25 1482	25 1483 / 25 1573	25 1552	20 1643	25 1640	25 1641	25 1642	25 1738	25 1739
72	1	-	Sechskantschraube M 6 x 12 DIN 933 - 8,8 Zn 8 Hexagon bolt Sextantskruv Vis à six pans	H	●	●		●	●	●	●	●	●
73	12	-	Blechschaube B 3,9 x 9,5 DIN 7981 Zn 12 Sheet-metal screw Plåtskruv Vis Parker	H	●	●		●	●	●	●	●	●
74	2	-	Blechschaube B 4,8 x 13 DIN 7981 Zn 12 Sheet-metal screw Plåtskruv Vis Parker	H	●	●		●	●	●	●	●	●
75	3	100	Blechschaube B 6,3 x 13 Sheet-metal screw Plåtskruv Collier de serrage	108 10 248	●	●		●	●	●	●	●	●
76	12	-	Federscheibe B 4 DIN 137 Zn 12 Spring Lockwasher Fjäderbricka Rondelle élastique	H	●	●		●	●	●	●	●	●
77	2	-	Federscheibe B 5 DIN 137 Zn 12 Spring Lockwasher Fjäderbricka Rondelle élastique	H	●	●		●	●	●	●	●	●
78	10	-	Kabelband - Fa. Raymond - Nr. 12 Cable band Kabelband Attache-câble	H	●	●		●	●	●	●	●	●
79	5	-	Kabelbefestiger Cable mount Kabelfastsättning Bride de fixation de câble	H	●	●		●	●	●	●	●	●
80	1	-	Kabelschuh A 8 - 6 DIN 46 225 Sn 8 Eye Kabelskop Cosse de câble	H	●	●		●	●	●	●	●	●
81	2	-	Kabelschuh A 6 - 6 DIN 46 225 Sn 8 Eye Kabelskop Cosse de câble	H	●	●		●	●	●	●	●	●
82	3	-	Steckhülse Socket Stiftskåpa Duille à fiche plate	206 53 010	●	●		●	●	●	●	●	●
83	7	-	Steckhülse AMP-Nr. 160 256-7 Socket Stiftskåpa Duille à fiche plate	H	●	●		●	●	●	●	●	●

Bild-Nr. Fig. No. Bild nr. Fig. No.	Stückzahl pro Gerät Req. per heater Styck per aggregat Quantité par appareil	Stückzahl pro VE Pkg. count Styck par beställning- senhet Quantité minimale	Benennung Designation Benämning Désignation	Bestell-Nr. Order No. Beställningsnr. No. Référence	H	25 1482	25 1483 / 25 1573	25 1552	20 1643	25 1640	25 1641	25 1642	25 1738	25 1739
84	3	-	Steckhülse AMP-Nr. 160 301-7 Socket Stiftskåpa Duille à fiche plate		H	•	•		•	•	•	•	•	•
85	1	1	Steckhülsegehäuse Socket housing Stickkontakthylsa Chemise de la douille à fiche plate	206 31 303		•	•		•	•	•	•	•	•
86	1	1	Distanzplatte Plate Platta Plaqua	25 1482 89 00 02		•	•		•	•	•	•	•	•
87	1	1	Flanschdichtung Sealing Packning Joint	25 1482 89 00 03		•	•		•	•	•	•	•	•
88	1	1	Übergangsstück 24/26 Transition piece Övergång Élément de passage	25 1482 89 00 04		•	•		•	•	•	•	•	•
89	1	1	Rohrbogen Pipe bend Rörböj Courbure	25 1482 89 00 05 25 1226 89 36 00		•	•	•	•	•	•	•	•	•
90	1	-	Universalschalter, vollst. Universal switch Universalbrytare Commutateur universel	25 1380 89 04 00		•	•		•	•	•	•		
91	1	1	Glühlampe 12 V Lamp bulb Glödlampa Lampe à incandescence	207 00 005		•			•	•				
-	1	1	Glühlampe 24 V Lamp bulb Glödlampa Lampe à incandescence	207 00 006			•		•	•	•			
92	1	1	Heizungschaltuhr Heater timer Värmaretidur Minuterie de chauffage	12 V 25 1482 89 19 00 24 V 25 1483 89 02 00		•	•		•	•		•	•	•
92 a	1	1	Heizungsschaltuhr Heater timer Värmaretidur Minuterie de chauffage	12 V 25 1482 89 25 00 24 V 25 1483 89 10 00		•	•		•	•		•	•	•
92 b	1	1	Befestigungsteile Holder Hållöre Support de minuterie	25 1482 70 01 00		•	•		•	•	•	•	•	•



Bild-Nr. Fig. No. Bild nr. Fig. No.	Stückzahl pro Gerät Req. per heater Styck per aggregat Quantité par appareil	Stückzahl pro VE Pkg. count Styck par beställning- senhet Quantité minimale	Benennung Designation Benämning Désignation	Bestell-Nr. Order No. Beställningsnr. No. Référence	25 1482 / 25 1573												
					25 1482	25 1483	25 1552	20 1643	25 1640	25 1641	25 1642	25 1738	25 1739				
93	1	1	Raumtemperaturregler Room thermostat Rumtemperaturreglage Thermostat d'ambiance	schwarz black svart noir	25 1557 80 01 00	●	●	●	●	●	●	●					
-	1	1	Raumtemperaturregler Room thermostat Rumtemperaturreglage Thermostat d'ambiance	braun brown brun brun	25 1557 80 07 00	●	●	●	●	●	●	●					
94	1	1	Endhülse End sleeve Ändhylsa Douille finale		25 1482 80 00 01	●	●		●	●	●	●					
-	1	1	Tankanschluß Tank connection Tankanslutning Raccord au réservoir		25 1552 80 01 00	●	●	●									
95	1	1	Gehäuse Housing Skyddskåppa Boîtier		20 1643 01 00 05				●								
96	1	1	Konsole Holder Befästning Support		20 1643 01 00 06				●								
97	1	1	Kontaktfeder Contact spring Kontaktfjäder Ressort de contact		20 1643 01 00 07				●								
98	1	1	Tülle Sleeve Genomföring Passe-câble		20 1643 01 00 08				●								
99	2	1	Tülle Sleeve Genomföring Passe-câble		20 1643 01 00 09				●								
100	1	1	Klammer Clip Klämna Cavalier		151 22 051				●								
101	1	1	Zündleistungsstecker Ignition line plug Tändledningskontakt Cosse du câble d'allumage		206 00 150				●								

Bild-Nr. Fig. No.	Stückzahl pro Gerät Req. per heater Styck per aggregat Quantité par appareil	Stückzahl kpro VE Pkg. count Styck par beställning- senhet Quantité minimale	Benennung Designation Benämning Désignation	Bestell-Nr. Order No. Beställningsnr. No. Référence	25 1482 / 25 1573												
					25 1482	25 1483	25 1552	20 1643	25 1640	25 1641	25 1642	25 1738	25 1739				
102	1	1	Reduzierbüchse Spacer Distansmetallanläggsbricka Entretoise	206 31 019					●								
103	n. B. As req'd e. b. selon besoin	lfdm by metre löp. m au metre	Dichtungsband Sealing tape Isoleringsband Joint d'étanchéité	328 00 110					●								
104	1	1	Klammer Clip Klämma Agrafe	151 32 101					●								
105	1	1	Kerzenanschluß Connection Anslutningsdel Embout	25 1384 99 03 00		●				●	●	●	●	●			
106	1	1	Stromregler Current regulator Strömregulator Régulateurs de tension	12 V 25 1482 89 20 01 24 V 25 1483 89 03 01						●			●	●			
107	1	1	Rohrscheile Pipe Clip Rörklämma Collier de serrage	152 00 139	●	●		●	●	●	●	●					
108	1	1	Leitungsstrang Cable section Kabelsträng Faisceau de câbles	20 1579 80 04 00	●	●	●	●	●	●	●	●	●	●	●	●	●
109	1	1	Leitungsstrang Cable section Kabelsträng Faisceau de câbles	25 1688 80 04 00											●	●	
110	1	1	Leitungsstrang Cable section Kabelsträng Faisceau de câbles	25 1482 80 01 00	●	●	●	●	●	●	●	●	●	●	●	●	●
111	1	1	Bedieneinrichtung Operating unit Manöverdon Instrument de commande	12 V 25 1767 71 00 00 24 V 25 1768 71 00 00											●	●	
112	2	20	Steckverbinder Plug-socket-connector Skarvstycke Connecteur	206 00 040	●	●	●	●	●	●	●	●	●	●	●	●	●





Bild-Nr. Fig. Nr. Bild nr. Fig. No.	Stückzahl pro Gerät Req. per heater Styck per aggregat Quantité par appareil	Stückzahl kpro VE Pkg. count Styck par beställning- senhet Quantité minimale	Benennung Designation Benämning Désignation	Bestell-Nr. Order No. Beställningsnr. No. Référence	25 1482 / 25 1573										
					25 1482	25 1483	25 1552	20 1643	25 1640	25 1641	25 1642	25 1738	25 1739		
113	-	-	Steckhülsegehäuse Socket housing Stickkontakthylsa Chemise de la douille à fiche plate	206 31 303	●	●		●	●	●	●	●	●		
114	-	-	Steckhülse Socket connections Flatstifthylsa Prise femelle	206 36 151									●	●	
115	-	-	Flachstecker Flat-pin terminal Flatstift Fiche plate	206 73 016									●	●	
116	-	-	Flachsteckerführung Flat-pin guide Flatstiftstyrning Guide-fiche	206 31 014									●	●	
117	1	1	Temperaturfühler, extern Temperature sensor, external Temperaturkännare, extern Sonde de température, externe	25 1482 89 45 00									●	●	
118	1	1	Leitungsstrang (4 m lang) Cable section Kabelsträng Faisceau de câbles	25 1688 89 09 00									●	●	
119	2	1	Abdeckung Cover Kåpa Calotte	204 31 005									●	●	
120	1	1	Sicherungseinsatz 25 A Fuse Säkringsinsats Cartouche fusible	204 00 089									●	●	
121	1	1	Doppelflachfeder-Kontakt Twin leaf-spring contact Dubbelbladfjäderkontakt Contact bi-lames	206 73 058									●	●	
122	2	1	Unterteil Bottom section Underdel Embase	204 31 004									●	●	
123	1	1	Leitungsstrang Cable section Kabelsträng Faisceau de câbles	25 1738 0108 00									●	●	